

ElectroPuls™ | E10000 Linear-Torsion All-Electric Dynamic Test Instrument

The ElectroPuls™ E10000 Linear-Torsion is a state-of-the-art, all-electric test instrument designed for dynamic and static testing on a wide range of materials and components. It includes Instron® advanced digital control electronics, bi-axial Dynacell™ load cell, Console software, and the very latest in testing technology – hassle-free tuning based on specimen stiffness, electrically operated crosshead lifts, a T-slot table for flexible test set ups and a host of other user-orientated features. Powered from a single-phase supply it requires no additional utilities for basic machine operation (for example, pneumatic air, hydraulics, or water).

Features

- Oil-Free linear and rotary motor technology for clean conditions
- De-coupled linear/rotary actuators
- Designed for both dynamic and static testing on a variety of materials and components
- High dynamic performance, Capable of performing up to 100 Hz
- ± 10 kN dynamic linear load capacity and ± 100 Nm dynamic torque capacity
- Electrically powered from single phase main supply, no need for hydraulic or pneumatic air supplies
- Temperature-controlled air-cooling system
- High-stiffness, precision-aligned twin column load frame with actuator in upper crosshead
- Versatile T-slot table for regular and irregular grips and specimens
- Compact instrument - frame requires less than 0.8 m² (8.6 ft²) of floor space

Hardware and Software Interfaces Designed to Put You in Control

- Console software control interface - engineered with Instron's knowledge of machine usability
- Rigidly mounted control pod with critical controls and emergency stop at your fingertips
- Electrically powered crosshead lift system with manual lever clamps for ease of test space adjustment
- System Status Indicator shows system conditions (off, on, emergency stop, and fault)

Hidden Technology Designed to Improve Your Test

- Patented, stiffness-based loop tuning system in both axes
- Unique actuator bearing system that maintains load string alignment when offset or lateral loads are induced by specimens or fixtures
- An optical encoder for precise digital extension control and a dedicated position channel for set up and end of test
- Digital two-axis controller based on the industry's most advanced controller
- Dynacell advanced load cell technology for faster testing and reduction of inertial errors

A High Level of Versatility

- Readily adjustable test space to suit a wide variety of specimens, grips, fixtures, and accessories
- 60 mm (2.36 in) linear stroke, $\pm 135^\circ$ rotation for a wide range of tests, as well as ease of specimen set up
- Twin column configuration provides easy access to the test area
- Compatible with WaveMatrix™, Bluehill® 3 and Application Specific software
- Compatible with a large range of grips, fixtures, chambers, saline baths, video extensometers, and other accessories



Specifications

Linear Dynamic Capacity	±10 kN (±2250 lbf)
Linear Static Capacity	±7 kN (±1570 lbf)
Torsional Capacity	±100 Nm (±800 in-lb)
Stroke	60 mm (2.36 in)
Rotation	±135° as standard, ±16 revolutions
Load Weighing Accuracy	±0.5 % of indicated load or ±0.005 % of load cell capacity, whichever is greater
Daylight Opening	877 mm (34.5 in) maximum with actuator at mid stroke
Configuration	Twin-column with actuator in upper crosshead
Mounting	Floor: Vertical
Lift and Locks	Electrically powered lifts with manual lever clamps
Load Cell	±10 kN ±100 Nm Dynacell™ mounted to base
Weight	994 kg (2190 lb) [frame] 40 kg (88 lb) [controller]
Electrical Supply	208 VAC to 240 VAC 32A single phase 50/60 Hz
Cooling	Temperature-controlled air cooling
Operating Temperature	+10 to +30°C (+50 to +86°F)

INTERFACES

Actuator	M20 × 1.5 central thread 6 × M8 on 75 mm PCD 6 × M8 clearance holes on 75 mm PCD
T-Slot Table	M12 × 1 right hand central thread 3 × M6 holes on 57 mm PCD 6 × M10 holes on 100 mm PCD 3 × M10 holes on 125 mm PCD 4 × M10 holes on a 280 mm × 90 mm accessory rectangle 4 × M6 T-slots spaced 80 mm from center

Accessories

1300-303	Safety screen for E10000 Test Instrument
2718-012 ¹	High-Pressure Pneumatic grip air kit for E10000
2718-014 ²	High-Pressure Pneumatic grip air kit for E10000
2742-206	±3 kN ±25 Nm Linear-Torsion Mechanical Wedge-Action Grips
2742-305	±10 kN ±100 Nm Linear-Torsion Pneumatic Wedge-Action Grips
3117-080	Electropuls Pullrod kit
3119-605 ³	Environmental Chamber
2810-500	3-Point Bend Fixture
2810-505	4-Point Bend Conversion Kit
2840-030	10 kN Compression Platens

Notes: 1. Only compatible with 8800 Tower Controller
2. Only compatible with 8800MT Controller
3. Requires Pull-rods & Mounting Brackets

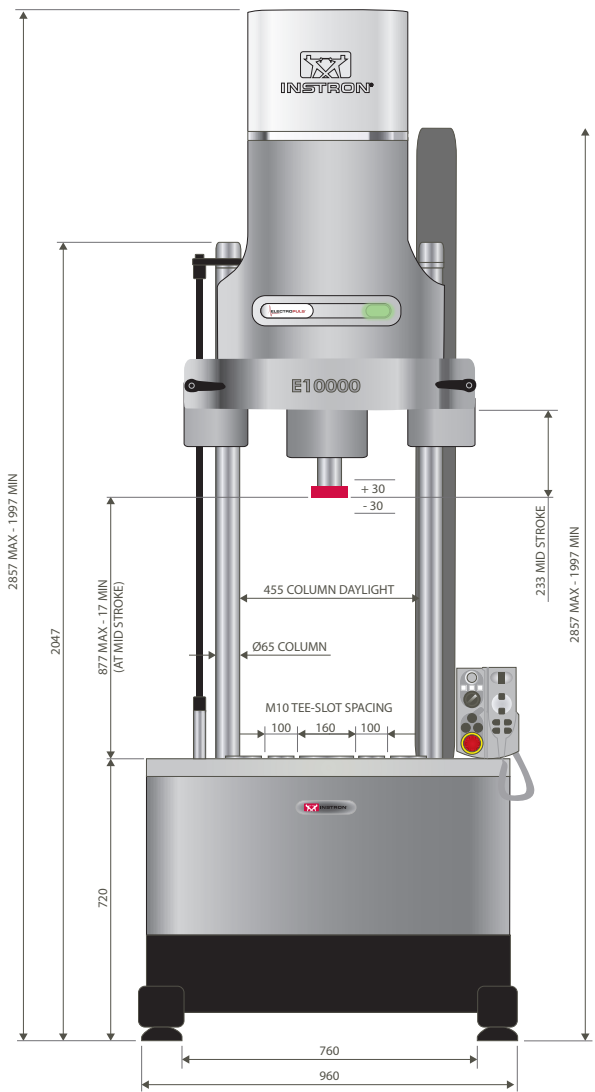

E10000 Linear-Torsion dimensions: front view

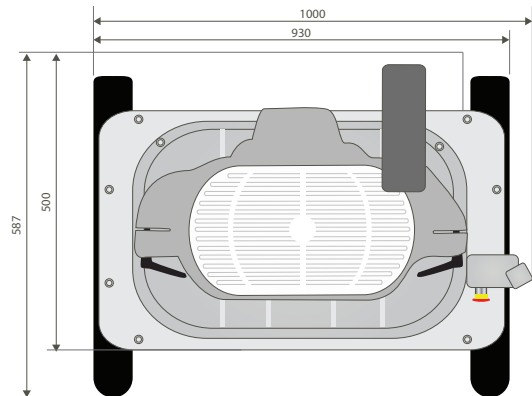

E10000 Linear-Torsion dimensions: plan view

www.instron.com



Worldwide Headquarters
825 University Ave, Norwood, MA 02062-2643, USA
Tel: +1 800 564 8378 or +1 781 575 5000

European Headquarters
Coronation Road, High Wycombe, Bucks HP12 3SY, UK
Tel: +44 1494 464646

Instron Industrial Products
900 Liberty Street, Grove City, PA 16127, USA
Tel: +1 724 458 9610