

CHIP CLASSIFIER CC-100 model



For quick and reproducible classification and analysis of wood chips.

Applicable standards: TAPPI UM 21 - SCAN CM 40:88

Test description:

The Chip Classifier CC-100 is used for rapid and reproducible and accurate classification of wood chip in size and thickness distribution for the production of chemical or mechanical pulps by using standard size screening trays mounted on a shaking mechanism with specified frequency.

A weighted quantity of the sample put in the upper screening tray with chip fractionates through different diameters and wide slots screens and is shaken in horizontal plain with specified frequency. The fractionated chips collected from each screen are weighted and the contents from each screen can be calculated in % (percentage)

-  Chip Quality Optimization Tool
-  Improves Quality of Pulp
-  Robust Chip Classifier



SPECIFICACIONES

- Timer: 15 minutes Analog
- Mounting: Unit is self-supporting and does not require floor bolting
- Pesos: Bandejas de clasificación
 - Round hole 2,5 to 3,5 kg each
 - Bar 3,5 to 4,5 kg each
- Base 60 kg
- Optional: Digital Scale

The chip classifier is supplied with dust collection tray and 5 standard classification trays:

- No. 1 – with 45 mm (1,771") diameter holes, triangular pitch 60 mm (2,362")
- No. 2 – with 13 mm (.512") diameter holes
- No. 3 – with 8 mm (.315") wide slots
- No. 4 – with 7 mm (.276") diameter holes, triangular pitch 8,5 mm (.335")
- No. 5 – with 3 mm (.118") diameter holes, triangular pitch 8 mm (.315")
- No. 6 – dust pan collection

TRAY SIZES AVAILABLE:

ROUND HOLE TRAYS		
1/8	1 1/8"	3 mm
3/16	1 1/4"	5 mm
1/4"	1 3/8"	7 mm
3/8"	1 1/2"	11 mm
1/2"	1 5/8"	15 mm
5/8"	1 3/4"	16 mm
3/4"	1 7/8"	30 mm
7/8"	2"	45 mm
1"		
BAR TRAYS		
2 mm	5 mm	8 mm
3 mm	6 mm	9 mm
4 mm	7 mm	10 mm

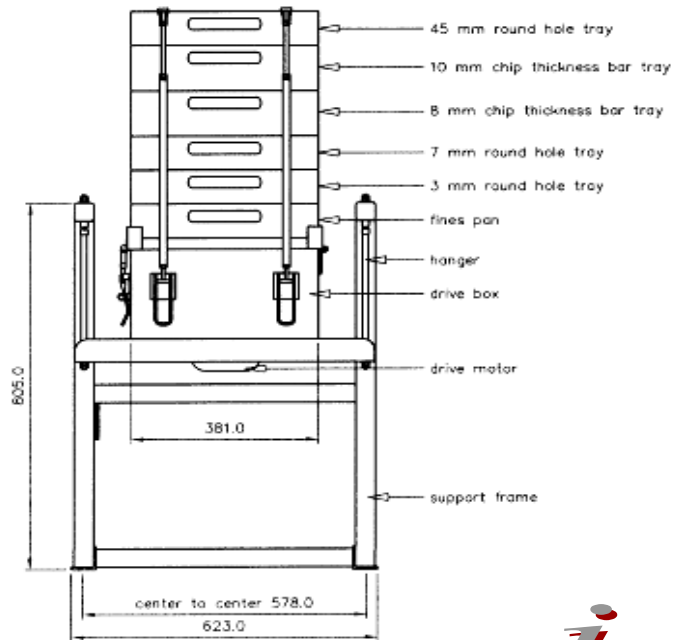
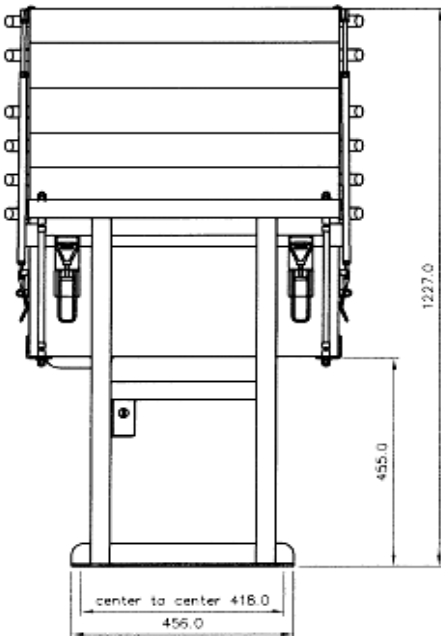
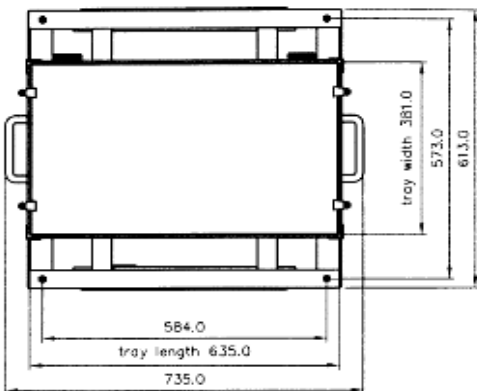

CONNECTIONS:

Electrical: 110V/60Hz ó 220V/50Hz Single-phase 0,18 Kw

DIMENSIONS AND WEIGHT

Dimensions: 635 mm x 625 mm x 1003 mm (W x D x H)

Box for Transport : 1000 x 1000 x 1750 mm (W x D x H)

Weight Net/Gross 70 Kg / 140 Kg

DELIVERY CONTENT:

- > CHIP CLASSIFIER CC100
- > 1 Dust pan collection (lower)
- > 5 standard classification trays

* TECHLAB SYSTEMS reserves the right to do any technical modification without advance notice